

Current Transducer DHR-C5

For the electronic measurement of currents: DC, AC, pulsed..., with galvanic separation between the primary circuit and the secondary circuit.

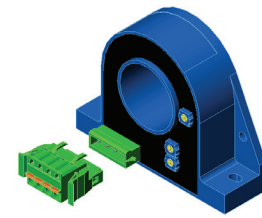

$I_{PN} = 100 \dots 400 \text{ A}$



Electrical data

Type	Primary current, measuring range ¹⁾	Primary nominal RMS current	
	I_{PM} (A)	I_{PN} (A)	
DHR 100 C5	±600	100	
DHR 200 C5	±600	200	
DHR 300 C5	±1000	300	
DHR 400 C5	±1000	400	
U_{out}	Output voltage	0 ... 5	V DC
R_L	Load resistance	≥ 10	kΩ
U_C	Supply voltage ²⁾	+20 ... 50	V DC
I_C	Current consumption	30	mA
U_{SL}	Output voltage limitation	< 14	V
\hat{I}_{Pmax}	Maximum withstand primary peak current	30000	At

Accuracy - Dynamic performance data

ϵ_{tot}	Total error @ $I_{PN}, T_A = 25 \text{ °C}$ (excluding offset)	< ±1	%
ϵ_L	Linearity error (1 % of $I_{PN} \dots I_{PN}$)	< ±1.0	%
U_{OE}	Electrical offset voltage @ $T_A = 25 \text{ °C}$	< ±100	mV
TCU_{OE}	Temperature coefficient of U_{OE} (0 ... +60 °C)	±2.0	mV/K
	(-40 ... +70 °C)	±4.0	mV/K
TCU_{out}	Temperature coefficient of U_{out} (% of reading)	±0.1	%/K
t_{D90}	Delay time to 90 % of the final output value for I_{PN} step	< 150	ms
BW	Frequency bandwidth (±1 dB)	DC 20 ... 6000	Hz

General data

T_A	Ambient operating temperature	-40 ... +70	°C
T_{Ast}	Ambient storage temperature	-40 ... +85	°C
m	Mass	260	g
IPxx	Protection degree	IP20	

Notes: ¹⁾ I_{PM} is the highest peak level of the primary signal that is taken into account for accurate true RMS calculation. Yet the device is designed for maximum continuous true RMS value equal to I_{PN} , whereas the output is limited by the above specified output limitation

²⁾ According to the UL 508 Standard for Safety for Industrial Control Equipment, the supply voltage must not exceed 42 V DC

³⁾ Deviation of the offset during the test IEC 61000-4-3 between 100 MHz and 1000 MHz

⁴⁾ Deviation of the offset during the test IEC 61000-4-6 between 150 kHz and 80 MHz.

Features

- VFD and SCR waveforms current measurement
- True RMS output
- Panel mounting
- Eliminates insertion loss
- Insulating plastic case recognized according to UL 94-V0.

Advantages

- Large aperture for cable up to Ø 32 mm
- High insulation between primary and secondary circuits
- Easy installation.

Applications

- **VFD Controlled Loads**
VFD output indicates how the motor and attached load are operating
- **SCR Controlled Loads**
Accurate measurement of phase angle fired or burst fired (time proportioned) SCRs. Current measurement gives faster response than temperature measurement
- **Switching Power Supplies and Electronic Ballasts**
True RMS sensing is the most accurate way to measure power supply or ballast input power.

Application Domain

- Energy and Automation.

Current Transducer DHR-C5

Insulation coordination

U_{Nm}	Rated insulation RMS voltage ¹⁾ according to the standard IEC 61010-1 and with the following conditions: - Reinforced insulation - Over voltage category CAT III - Pollution degree PD2 - Heterogeneous field	300	V
U_d	RMS voltage for AC insulation test ²⁾ , 50 Hz, 1 min	4.0	kV
U_{Ni}	Impulse withstand voltage 1.2/50 μ s	7.3	kV
d_{Cp}	Creepage distance	7.2	mm
d_{Cl}	Clearance	7.2	mm
CTI	Comparative tracking index (group I)	> 600	

Notes: ¹⁾ Between primary conductor voltage and ground. The voltage category could be improved according to the insulation characteristic given by the cable manufacturer. The UL 508 Standard for Safety for Industrial Control Equipment requires that only insulated conductors are used as primary circuit with this transducer

²⁾ Between primary (completely filling the aperture) and secondary.

Transfer characteristics

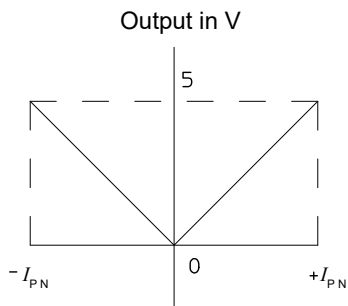

Current Transducer DHR-C5

Safety

This transducer must be used in limited-energy secondary circuits according to IEC 61010-1.



This transducer must be used in electric/electronic equipment with respect to applicable standards and safety requirements in accordance with the manufacturer's operating instructions.



Caution, risk of electrical shock

When operating the transducer, certain parts of the module can carry hazardous voltage (eg. primary busbar, power supply).

Ignoring this warning can lead to injury and/or cause serious damage.

This transducer is a build-in device, whose conducting parts must be inaccessible after installation. A protective housing or additional shield could be used.

Main supply must be able to be disconnected.

Dimensions DHR-C5 (in mm)

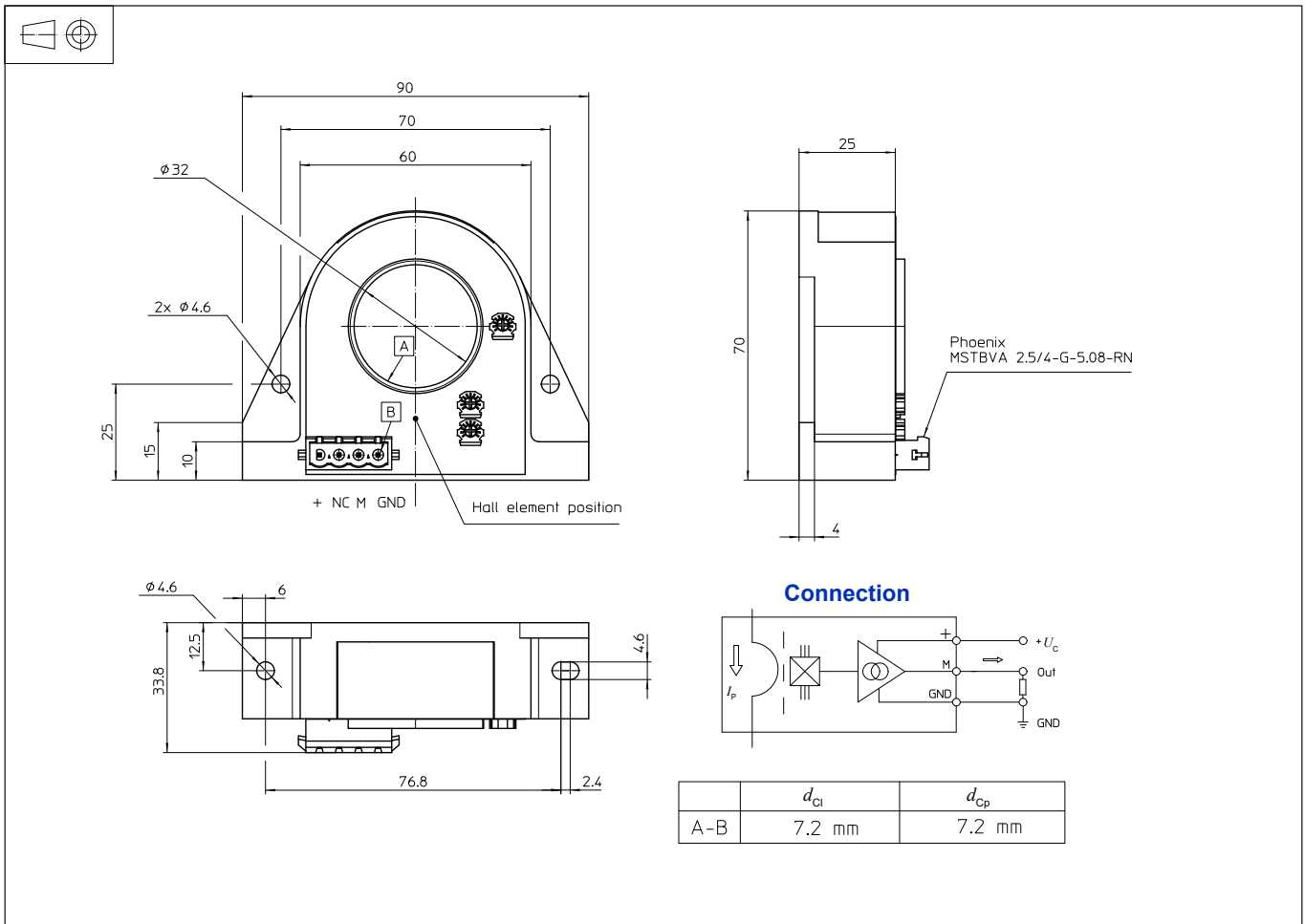

Connections

- Wires up to $\varnothing 2$ mm
- Female connector provided (spring terminal blocks)
- User-friendly spring-cage connection for no-tool direct conductor connection.

Mechanical characteristics

- General tolerance ± 1 mm
- Primary aperture $\varnothing 32.0$ mm
- Transducer fastening
 - Vertical
 - 1 hole and 1 notch $\varnothing 4.6$ mm
 - 2 steel screws M4
 - Horizontal
 - 2 holes $\varnothing 4.6$ mm
 - 2 steel screws M4
- Recommended fastening torque 0.75 N·m
- Distance between holes 70.0 mm & 78 mm

Remarks

- I_s is positive when I_p flows in the direction of the arrow.
- Temperature of the primary conductor should not exceed 90 °C.
- Installation of the transducer must be done unless otherwise specified on the datasheet, according to LEM Transducer Generic Mounting Rules. Please refer to LEM document N°ANE120504 available on our Web site: <https://www.lem.com/en/file/3137/download/>.
- Dynamic performances (di/dt and delay time) are best with a single bar completely filling the primary hole.
- This is a standard model. For different versions (supply voltages, turns ratios, unidirectional measurements...), please contact us.